



### [ Product Description ]

Our 1140 Litre (250 gallon) water storage tank is ideal for a wide range of applications, providing an effective solution for storing, transporting and dispensing water. The tough polyethylene tank and galvanised tubular steel base provide excellent durability; the base also includes integral forklift pockets for safe and easy lifting / moving. The large manway provides easy access to the tank for cleaning and maintenance.

This product is ideally suited for use in the following applications:

- ▶ Construction
- ▶ Industrial
- ▶ Council & municipal
- ▶ Agriculture



Pressure washer unit and hose reel



380mm diameter manway into top of tank

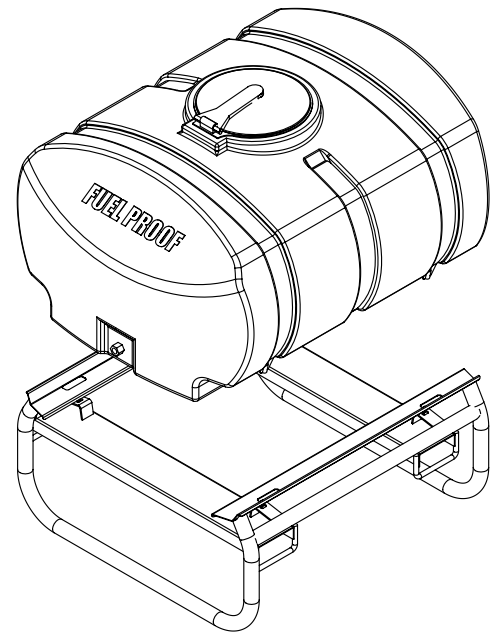

### [ Specification of unit shown ]

- ▶ 1140 litre (250 gallon capacity)
- ▶ Rotationally moulded polyethylene tank
- ▶ Galvanised tubular steel frame
- ▶ Integral forklift pockets
- ▶ Baffled tank for improved stability
- ▶ Secure lockable lid
- ▶ 2" bottom outlet for easy cleaning of unit
- ▶ 1" outlet front and rear
- ▶ 380mm diameter manway into top of tank
- ▶ Tank fitted with breather

### [ Technical Information ]

<b>Length:</b>	1520mm
<b>Width:</b>	1310mm
<b>Height:</b>	1390mm
<b>Capacity:</b>	1140 litres (250 gallons)
<b>Weight (empty):</b>	150kg
<b>Weight (full):</b>	1290kg

